



Please note that Cypress is an Infineon Technologies Company.

The document following this cover page is marked as “Cypress” document as this is the company that originally developed the product. Please note that Infineon will continue to offer the product to new and existing customers as part of the Infineon product portfolio.

Continuity of document content

The fact that Infineon offers the following product as part of the Infineon product portfolio does not lead to any changes to this document. Future revisions will occur when appropriate, and any changes will be set out on the document history page.

Continuity of ordering part numbers

Infineon continues to support existing part numbers. Please continue to use the ordering part numbers listed in the datasheet for ordering.

72-Mbit (2 M × 36) Flow-Through SRAM with NoBL™ Architecture

Features

- No Bus Latency™ (NoBL™) architecture eliminates dead cycles between write and read cycles
- Supports up to 133 MHz bus operations with zero wait states
- Data transfers on every clock
- Pin compatible and functionally equivalent to ZBT™ devices
- Internally self timed output buffer control to eliminate the need to use OE
- Registered inputs for flow through operation
- Byte Write capability
- 2.5-V I/O supply (V_{DDQ})
- Fast clock-to-output times
 - 6.5 ns (for 133-MHz device)
- Clock Enable (\overline{CEN}) pin to enable clock and suspend operation
- Synchronous self timed writes
- Asynchronous Output Enable (\overline{OE})
- CY7C1471BV25 available in JEDEC-standard Pb-free 100-pin TQFP package.
- Three Chip Enables (\overline{CE}_1 , CE_2 , \overline{CE}_3) for simple depth expansion.
- Automatic power down feature available using ZZ mode or CE deselect.
- Burst Capability – linear or interleaved burst order
- Low standby power

Selection Guide

Description	133 MHz	Unit
Maximum Access Time	6.5	ns
Maximum Operating Current	305	mA
Maximum CMOS Standby Current	120	mA

Functional Description

The CY7C1471BV25, is 2.5 V, 2 M × 36 synchronous flow through burst SRAMs designed specifically to support unlimited true back-to-back read or write operations without the insertion of wait states. The CY7C1471BV25, is equipped with the advanced No Bus Latency (NoBL) logic required to enable consecutive read or write operations with data transferred on every clock cycle. This feature dramatically improves the throughput of data through the SRAM, especially in systems that require frequent write-read transitions.

All synchronous inputs pass through input registers controlled by the rising edge of the clock. The clock input is qualified by the Clock Enable (\overline{CEN}) signal, which when deasserted suspends operation and extends the previous clock cycle. Maximum access delay from the clock rise is 6.5 ns (133-MHz device).

Write operations are controlled by two or four Byte Write Select (BW_x) and a Write Enable (\overline{WE}) input. All writes are conducted with on-chip synchronous self timed write circuitry.

Three synchronous Chip Enables (\overline{CE}_1 , CE_2 , \overline{CE}_3) and an asynchronous Output Enable (\overline{OE}) provide easy bank selection and output tristate control. To avoid bus contention, the output drivers are synchronously tristated during the data portion of a write sequence.

For a complete list of related documentation, click [here](#).

Logic Block Diagram – CY7C1471BV25

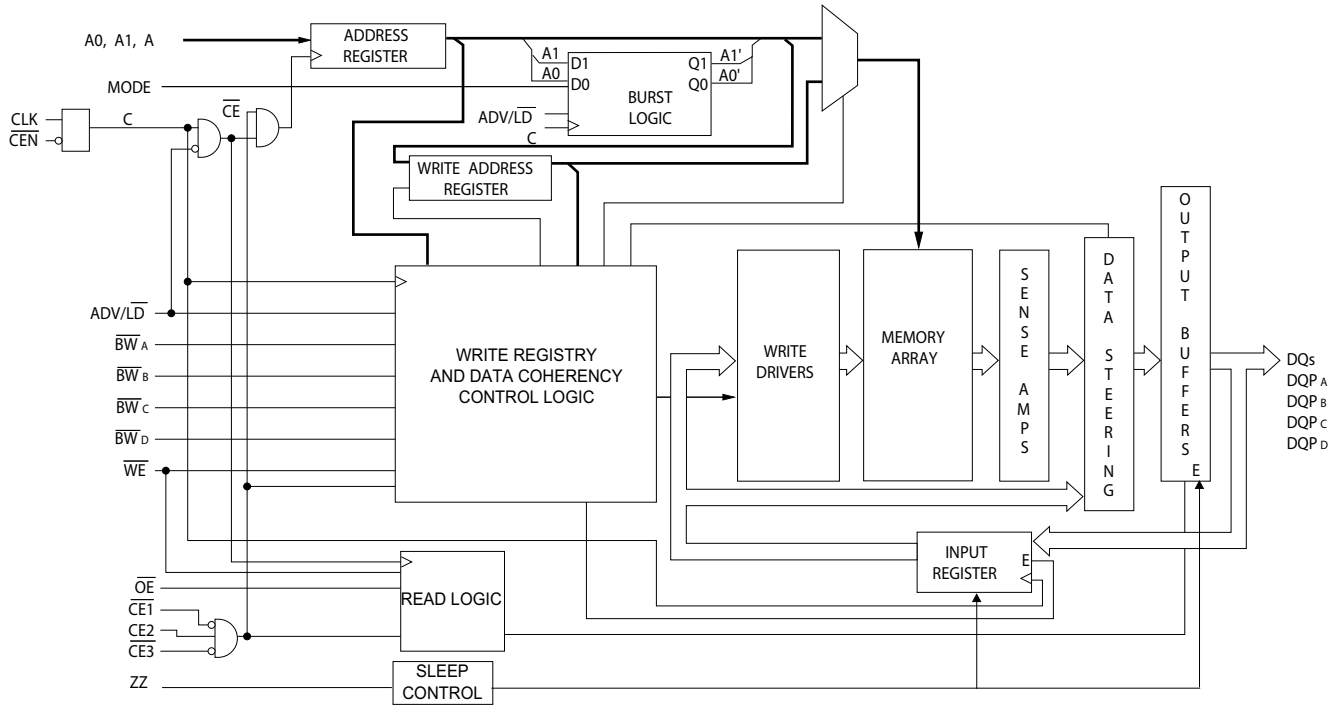

Contents

Pin Configurations	4	Thermal Resistance	11
Pin Definitions	5	AC Test Loads and Waveforms	11
Functional Overview	6	Switching Characteristics	12
Single Read Accesses	6	Switching Waveforms	13
Burst Read Accesses	6	Ordering Information	16
Single Write Accesses	6	Ordering Code Definitions	16
Burst Write Accesses	6	Package Diagrams	17
Sleep Mode	6	Acronyms	18
Interleaved Burst Address Table	7	Document Conventions	18
Linear Burst Address Table	7	Units of Measure	18
ZZ Mode Electrical Characteristics	7	Document History Page	19
Truth Table	8	Sales, Solutions, and Legal Information	21
Truth Table for Read/Write	9	Worldwide Sales and Design Support	21
Maximum Ratings	10	Products	21
Operating Range	10	PSoC® Solutions	21
Electrical Characteristics	10	Cypress Developer Community	21
Capacitance	11	Technical Support	21

Pin Configurations

Figure 1. 100-pin TQFP (14 × 20 × 1.4 mm) Pinout

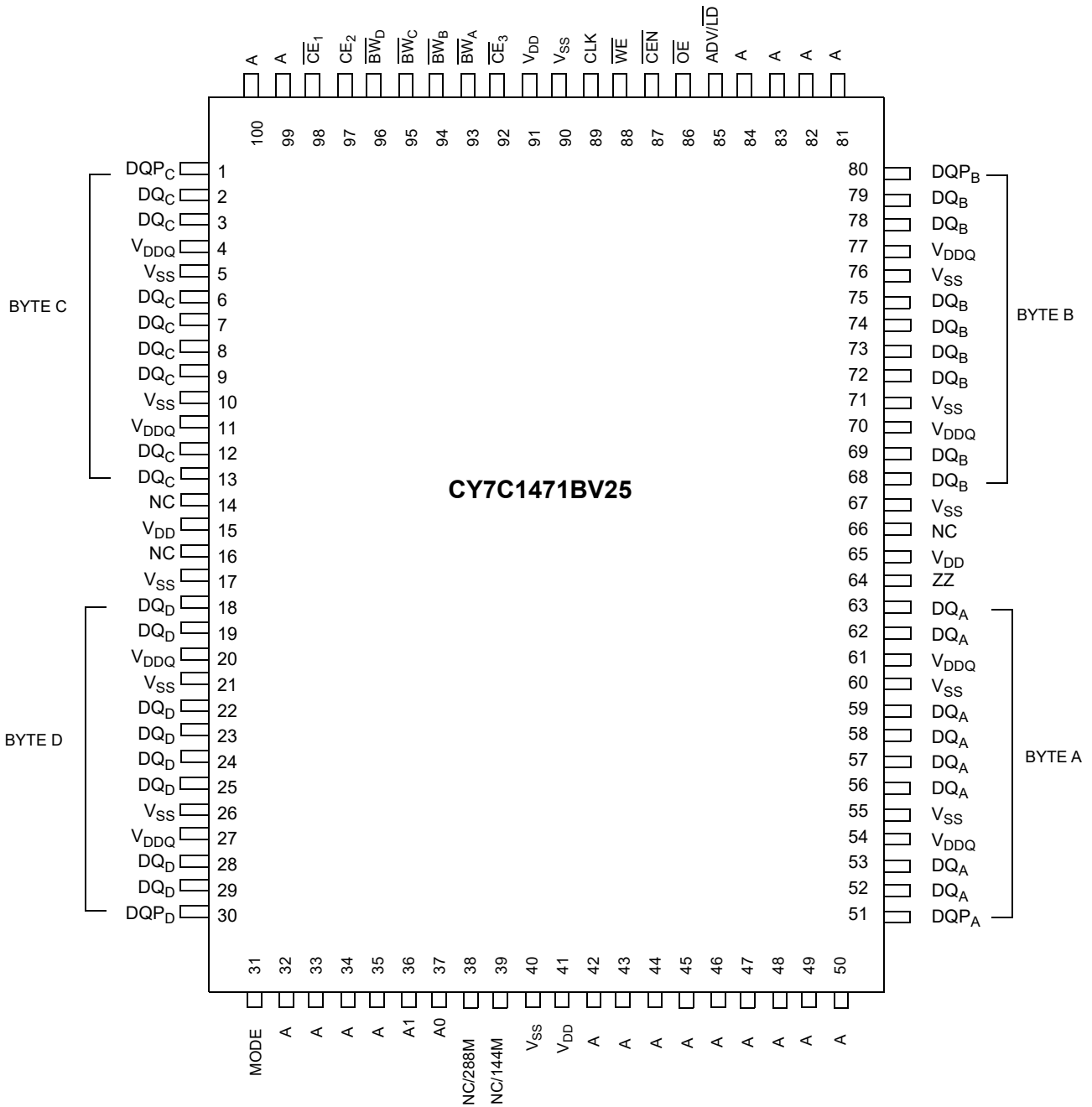

Pin Definitions

Name	I/O	Description
A ₀ , A ₁ , A	Input-Synchronous	Address Inputs Used to Select One of the Address Locations. Sampled at the rising edge of the CLK. A _[1:0] are fed to the two-bit burst counter.
\overline{BW}_A , \overline{BW}_B , \overline{BW}_C , \overline{BW}_D	Input-Synchronous	Byte Write Inputs, Active LOW. Qualified with \overline{WE} to conduct writes to the SRAM. Sampled on the rising edge of CLK.
\overline{WE}	Input-Synchronous	Write Enable Input, Active LOW. Sampled on the rising edge of CLK if \overline{CEN} is active LOW. This signal must be asserted LOW to initiate a write sequence.
ADV/LD	Input-Synchronous	Advance/Load Input. Used to advance the on-chip address counter or load a new address. When HIGH (and CEN is asserted LOW) the internal burst counter is advanced. When LOW, a new address can be loaded into the device for an access. After being deselected, ADV/LD must be driven LOW to load a new address.
CLK	Input-Clock	Clock Input. Captures all synchronous inputs to the device. CLK is qualified with \overline{CEN} . CLK is only recognized if \overline{CEN} is active LOW.
\overline{CE}_1	Input-Synchronous	Chip Enable 1 Input, Active LOW. Sampled on the rising edge of CLK. Used in conjunction with \overline{CE}_2 and \overline{CE}_3 to select or deselect the device.
\overline{CE}_2	Input-Synchronous	Chip Enable 2 Input, Active HIGH. Sampled on the rising edge of CLK. Used in conjunction with \overline{CE}_1 and \overline{CE}_3 to select or deselect the device.
\overline{CE}_3	Input-Synchronous	Chip Enable 3 Input, Active LOW. Sampled on the rising edge of CLK. Used in conjunction with \overline{CE}_1 and \overline{CE}_2 to select or deselect the device.
OE	Input-Asynchronous	Output Enable, Asynchronous Input, Active LOW. Combined with the synchronous logic block inside the device to control the direction of the I/O pins. When LOW, the I/O pins are enabled to behave as outputs. When deasserted HIGH, I/O pins are tristated, and act as input data pins. OE is masked during the data portion of a write sequence, during the first clock when emerging from a deselected state, when the device has been deselected.
\overline{CEN}	Input-Synchronous	Clock Enable Input, Active LOW. When asserted LOW the clock signal is recognized by the SRAM. When deasserted HIGH the clock signal is masked. Because deasserting \overline{CEN} does not deselect the device, \overline{CEN} can be used to extend the previous cycle when required.
ZZ	Input-Asynchronous	ZZ “Sleep” Input. This active HIGH input places the device in a non-time-critical “sleep” condition with data integrity preserved. For normal operation, this pin must be LOW or left floating. ZZ pin has an internal pull down.
DQ _s	I/O-Synchronous	Bidirectional Data I/O Lines. As inputs, they feed into an on-chip data register that is triggered by the rising edge of CLK. As outputs, they deliver the data contained in the memory location specified by the addresses presented during the previous clock rise of the read cycle. The direction of the pins is controlled by OE. When OE is asserted LOW, the pins behave as outputs. When HIGH, DQ _s and DQP _x are placed in a tristate condition. The outputs are automatically tristated during the data portion of a write sequence, during the first clock when emerging from a deselected state, and when the device is deselected, regardless of the state of OE.
DQP _x	I/O-Synchronous	Bidirectional Data Parity I/O Lines. Functionally, these signals are identical to DQ _s . During write sequences, DQP _x is controlled by \overline{BW}_x correspondingly.
MODE	Input Strap Pin	Mode Input. Selects the Burst Order of the Device. When tied to Gnd selects linear burst sequence. When tied to V _{DD} or left floating selects interleaved burst sequence.
V _{DD}	Power Supply	Power Supply Inputs to the Core of the Device.
V _{DDQ}	I/O Power Supply	Power Supply for the I/O Circuitry.
V _{SS}	Ground	Ground for the Device.
NC	–	No Connects. Not internally connected to the die. 144M, 288M, 576M, and 1G are address expansion pins and are not internally connected to the die.

Functional Overview

The CY7C1471BV25, is synchronous flow through burst SRAMs designed specifically to eliminate wait states during write read transitions. All synchronous inputs pass through input registers controlled by the rising edge of the clock. The clock signal is qualified with the Clock Enable input signal (\overline{CEN}). If \overline{CEN} is HIGH, the clock signal is not recognized and all internal states are maintained. All synchronous operations are qualified with \overline{CEN} . Maximum access delay from the clock rise (t_{CDV}) is 6.5 ns (133-MHz device).

Accesses are initiated by asserting all three Chip Enables (\overline{CE}_1 , \overline{CE}_2 , \overline{CE}_3) active at the rising edge of the clock. If \overline{CEN} is active LOW and $\overline{ADV/LD}$ is asserted LOW, the address presented to the device is latched. The access is either a read or write operation, depending on the status of the Write Enable (\overline{WE}). Use Byte Write Select (\overline{BW}_X) to conduct Byte Write operations.

Write operations are qualified by the \overline{WE} . All writes are simplified with on-chip synchronous self-timed write circuitry.

Three synchronous Chip Enables (\overline{CE}_1 , \overline{CE}_2 , \overline{CE}_3) and an asynchronous Output Enable (\overline{OE}) simplify depth expansion. All operations (reads, writes, and deselections) are pipelined. $\overline{ADV/LD}$ must be driven LOW after the device is deselected to load a new address for the next operation.

Single Read Accesses

A read access is initiated when the following conditions are satisfied at clock rise:

- \overline{CEN} is asserted LOW
- \overline{CE}_1 , \overline{CE}_2 , and \overline{CE}_3 are ALL asserted active
- \overline{WE} is deasserted HIGH
- $\overline{ADV/LD}$ is asserted LOW.

The address presented to the address inputs is latched into the Address Register and presented to the memory array and control logic. The control logic determines that a read access is in progress and allows the requested data to propagate to the output buffers. The data is available within 6.5 ns (133-MHz device) provided \overline{OE} is active LOW. After the first clock of the read access, the output buffers are controlled by \overline{OE} and the internal control logic. \overline{OE} must be driven LOW to drive out the requested data. On the subsequent clock, another operation (read/write/deselect) can be initiated. When the SRAM is deselected at clock rise by one of the chip enable signals, the output is tristated immediately.

Burst Read Accesses

The CY7C1471BV25, has an on-chip burst counter that enables the user the ability to supply a single address and conduct up to four reads without reasserting the address inputs. $\overline{ADV/LD}$ must be driven LOW to load a new address into the SRAM, as described in the [Single Read Accesses](#) section. The sequence of the burst counter is determined by the MODE input signal. A LOW input on MODE selects a linear burst mode, a HIGH selects an interleaved burst sequence. Both burst counters use A_0 and A_1 in the burst sequence, and wraps around when incremented sufficiently. A HIGH input on $\overline{ADV/LD}$ increments the internal burst counter regardless of the state of chip enable inputs or \overline{WE} . \overline{WE} is latched at the beginning of a burst cycle. Therefore, the

type of access (read or write) is maintained throughout the burst sequence.

Single Write Accesses

Write accesses are initiated when these conditions are satisfied at clock rise:

- \overline{CEN} is asserted LOW
- \overline{CE}_1 , \overline{CE}_2 , and \overline{CE}_3 are ALL asserted active
- \overline{WE} is asserted LOW.

The address presented to the address bus is loaded into the Address Register. The write signals are latched into the Control Logic block. The data lines are automatically tristated regardless of the state of the \overline{OE} input signal. This allows the external logic to present the data on DQs and \overline{DQP}_X .

On the next clock rise the data presented to DQs and \overline{DQP}_X (or a subset for Byte Write operations, see [Truth Table for Read/Write on page 9](#) for details) inputs is latched into the device and the write is complete. Additional accesses (read/write/deselect) can be initiated on this cycle.

The data written during the write operation is controlled by \overline{BW}_X signals. The CY7C1471BV25, provides Byte Write capability that is described in the [Truth Table for Read/Write on page 9](#). The input \overline{WE} with the selected \overline{BW}_X input selectively writes to only the desired bytes. Bytes not selected during a Byte Write operation remain unaltered. A synchronous self-timed write mechanism is provided to simplify the write operations. Byte Write capability is included to greatly simplify read/modify/write sequences, which can be reduced to simple byte write operations.

Because the CY7C1471BV25, is common I/O devices, data must not be driven into the device while the outputs are active. The \overline{OE} can be deasserted HIGH before presenting data to the DQs and \overline{DQP}_X inputs. This tristates the output drivers. As a safety precaution, DQs and \overline{DQP}_X are automatically tristated during the data portion of a write cycle, regardless of the state of \overline{OE} .

Burst Write Accesses

The CY7C1471BV25, has an on-chip burst counter that makes it possible to supply a single address and conduct up to four Write operations without reasserting the address inputs. Drive $\overline{ADV/LD}$ LOW to load the initial address, as described in [Single Write Accesses on page 6](#). When $\overline{ADV/LD}$ is driven HIGH on the subsequent clock rise, the Chip Enables (\overline{CE}_1 , \overline{CE}_2 , and \overline{CE}_3) and \overline{WE} inputs are ignored and the burst counter is incremented. You must drive the correct \overline{BW}_X inputs in each cycle of the Burst Write to write the correct data bytes.

Sleep Mode

The ZZ input pin is an asynchronous input. Asserting ZZ places the SRAM in a power conservation “sleep” mode. Two clock cycles are required to enter into or exit from this “sleep” mode. While in this mode, data integrity is guaranteed. Accesses pending when entering the “sleep” mode are not considered valid nor is the completion of the operation guaranteed. You must select the device before entering the “sleep” mode. \overline{CE}_1 , \overline{CE}_2 , and \overline{CE}_3 , must remain inactive for the duration of t_{ZZREC} after the ZZ input returns LOW.

Interleaved Burst Address Table

 (MODE = Floating or V_{DD})

First Address A1:A0	Second Address A1:A0	Third Address A1:A0	Fourth Address A1:A0
00	01	10	11
01	00	11	10
10	11	00	01
11	10	01	00

Linear Burst Address Table

(MODE = GND)

First Address A1:A0	Second Address A1:A0	Third Address A1:A0	Fourth Address A1:A0
00	01	10	11
01	10	11	00
10	11	00	01
11	00	01	10

ZZ Mode Electrical Characteristics

Parameter	Description	Test Conditions	Min	Max	Unit
I_{DDZZ}	Sleep mode standby current	$ZZ \geq V_{DD} - 0.2 V$	–	120	mA
t_{ZZS}	Device operation to ZZ	$ZZ \geq V_{DD} - 0.2 V$	–	$2t_{CYC}$	ns
t_{ZZREC}	ZZ recovery time	$ZZ \leq 0.2 V$	$2t_{CYC}$	–	ns
t_{ZZI}	ZZ active to sleep current	This parameter is sampled	–	$2t_{CYC}$	ns
t_{RZZI}	ZZ Inactive to exit sleep current	This parameter is sampled	0	–	ns

Truth Table

The truth table for CY7C1471BV25 follows. [1, 2, 3, 4, 5, 6, 7]

Operation	Address Used	\overline{CE}_1	\overline{CE}_2	\overline{CE}_3	ZZ	ADV/LD	\overline{WE}	\overline{BW}_x	OE	CEN	CLK	DQ
Deselect Cycle	None	H	X	X	L	L	X	X	X	L	L->H	Tristate
Deselect Cycle	None	X	X	H	L	L	X	X	X	L	L->H	Tristate
Deselect Cycle	None	X	L	X	L	L	X	X	X	L	L->H	Tristate
Continue Deselect Cycle	None	X	X	X	L	H	X	X	X	L	L->H	Tristate
Read Cycle (Begin Burst)	External	L	H	L	L	L	H	X	L	L	L->H	Data Out (Q)
Read Cycle (Continue Burst)	Next	X	X	X	L	H	X	X	L	L	L->H	Data Out (Q)
NOP/Dummy Read (Begin Burst)	External	L	H	L	L	L	H	X	H	L	L->H	Tristate
Dummy Read (Continue Burst)	Next	X	X	X	L	H	X	X	H	L	L->H	Tristate
Write Cycle (Begin Burst)	External	L	H	L	L	L	L	L	X	L	L->H	Data In (D)
Write Cycle (Continue Burst)	Next	X	X	X	L	H	X	L	X	L	L->H	Data In (D)
NOP/Write Abort (Begin Burst)	None	L	H	L	L	L	L	H	X	L	L->H	Tristate
Write Abort (Continue Burst)	Next	X	X	X	L	H	X	H	X	L	L->H	Tristate
Ignore Clock Edge (Stall)	Current	X	X	X	L	X	X	X	X	H	L->H	-
Sleep Mode	None	X	X	X	H	X	X	X	X	X	X	Tristate

Notes

1. X = "Don't Care." H = Logic HIGH, L = Logic LOW. $\overline{BW}_x = L$ signifies at least one Byte Write Select is active, $\overline{BW}_x = \text{Valid}$ signifies that the desired Byte Write Selects are asserted, see [Truth Table for Read/Write on page 9](#) for details.
2. Write is defined by \overline{BW}_x , and \overline{WE} . See [Truth Table for Read/Write on page 9](#).
3. When a write cycle is detected, all IOs are tristated, even during byte writes.
4. The DQs and \overline{DQP}_x pins are controlled by the current cycle and the \overline{OE} signal. \overline{OE} is asynchronous and is not sampled with the clock.
5. $\overline{CEN} = H$, inserts wait states.
6. Device powers up deselected with the IOs in a tristate condition, regardless of \overline{OE} .
7. \overline{OE} is asynchronous and is not sampled with the clock rise. It is masked internally during write cycles. During a read cycle DQs and $\overline{DQP}_x = \text{tristate}$ when \overline{OE} is inactive or when the device is deselected, and DQs and $\overline{DQP}_x = \text{data}$ when \overline{OE} is active.

Truth Table for Read/Write

The read-write truth table for CY7C1471BV25 follows. [8, 9, 10]

Function	\overline{WE}	\overline{BW}_A	\overline{BW}_B	\overline{BW}_C	\overline{BW}_D
Read	H	X	X	X	X
Write No bytes written	L	H	H	H	H
Write Byte A – (DQ _A and DQP _A)	L	L	H	H	H
Write Byte B – (DQ _B and DQP _B)	L	H	L	H	H
Write Byte C – (DQ _C and DQP _C)	L	H	H	L	H
Write Byte D – (DQ _D and DQP _D)	L	H	H	H	L
Write All Bytes	L	L	L	L	L

Notes

8. X = "Don't Care." H = Logic HIGH, L = Logic LOW. $\overline{BW}_x = L$ signifies at least one Byte Write Select is active, $\overline{BW}_x = Valid$ signifies that the desired Byte Write Selects are asserted, see [Truth Table for Read/Write on page 9](#) for details.
9. Write is defined by \overline{BW}_x , and \overline{WE} . See [Truth Table for Read/Write on page 9](#).
10. This table is only a partial listing of the byte write combinations. Any combination of \overline{BW}_x is valid. Appropriate write is based on which byte write is active.

Maximum Ratings

Exceeding maximum ratings may impair the useful life of the device. These user guidelines are not tested.

Storage Temperature -65 °C to +150 °C
 Ambient Temperature with Power Applied -55 °C to +125 °C
 Supply Voltage on V_{DD} Relative to GND -0.5 V to +3.6 V
 Supply Voltage on V_{DDQ} Relative to GND -0.5 V to +V_{DD}
 DC Voltage Applied to Outputs in tristate -0.5 V to V_{DDQ} + 0.5 V

DC Input Voltage -0.5 V to V_{DD} + 0.5 V
 Current into Outputs (LOW) 20 mA
 Static Discharge Voltage (MIL-STD-883, Method 3015) > 2001 V
 Latch-up Current > 200 mA

Operating Range

Range	Ambient Temperature	V _{DD}	V _{DDQ}
Industrial	-40 °C to +85 °C	2.5 V – 5% / + 5%	2.5 V – 5% to V _{DD}

Electrical Characteristics

Over the Operating Range

Parameter ^[11, 12]	Description	Test Conditions	Min	Max	Unit
V _{DD}	Power Supply Voltage		2.375	2.625	V
V _{DDQ}	I/O Supply Voltage	For 2.5 V I/O	2.375	V _{DD}	V
V _{OH}	Output HIGH Voltage	For 2.5 V I/O, I _{OH} = -1.0 mA	2.0	-	V
V _{OL}	Output LOW Voltage	For 2.5 V I/O, I _{OL} = 1.0 mA	-	0.4	V
V _{IH}	Input HIGH Voltage ^[11]	For 2.5 V I/O	1.7	V _{DD} + 0.3 V	V
V _{IL}	Input LOW Voltage ^[11]	For 2.5 V I/O	-0.3	0.7	V
I _X	Input Leakage Current except ZZ and MODE	GND ≤ V _I ≤ V _{DDQ}	-5	5	μA
	Input Current of MODE	Input = V _{SS}	-30	-	μA
		Input = V _{DD}	-	5	μA
	Input Current of ZZ	Input = V _{SS}	-5	-	μA
Input = V _{DD}		-	30	μA	
I _{OZ}	Output Leakage Current	GND ≤ V _I ≤ V _{DDQ} , Output Disabled	-5	5	μA
I _{DD} ^[13]	V _{DD} Operating Supply Current	V _{DD} = Max, I _{OUT} = 0 mA, f = f _{MAX} = 1/t _{CYC}	-	305	mA
I _{SB1}	Automatic CE Power Down Current – TTL Inputs	V _{DD} = Max, Device Deselected, V _{IN} ≥ V _{IH} or V _{IN} ≤ V _{IL} , f = f _{MAX} , inputs switching	-	170	mA
I _{SB2}	Automatic CE Power Down Current – CMOS Inputs	V _{DD} = Max, Device Deselected, V _{IN} ≤ 0.3 V or V _{IN} ≥ V _{DD} - 0.3 V, f = 0, inputs static	-	120	mA
I _{SB3}	Automatic CE Power Down Current – CMOS Inputs	V _{DD} = Max, Device Deselected, V _{IN} ≤ 0.3 V or V _{IN} ≥ V _{DDQ} - 0.3 V, f = f _{MAX} , inputs switching	-	170	mA
I _{SB4}	Automatic CE Power Down Current – TTL Inputs	V _{DD} = Max, Device Deselected, V _{IN} ≥ V _{DD} - 0.3 V or V _{IN} ≤ 0.3 V, f = 0, inputs static	-	135	mA

Notes

11. Overshoot: V_{IH(AC)} < V_{DD} + 1.5 V (pulse width less than t_{CYC}/2). Undershoot: V_{IL(AC)} > -2 V (pulse width less than t_{CYC}/2).
12. T_{Power-up}: assumes a linear ramp from 0 V to V_{DD(min)} within 200 ms. During this time V_{IH} < V_{DD} and V_{DDQ} ≤ V_{DD}.
13. The operation current is calculated with 50% read cycle and 50% write cycle.

Capacitance

Parameter ^[14]	Description	Test Conditions	100-pin TQFP Max	Unit
C _{ADDRESS}	Address input capacitance	T _A = 25 °C, f = 1 MHz, V _{DD} = 2.5 V, V _{DDQ} = 2.5 V	6	pF
C _{DATA}	Data input capacitance		5	pF
C _{CTRL}	Control input capacitance		8	pF
C _{CLK}	Clock input capacitance		6	pF
C _{IO}	Input-Output capacitance		5	pF

Thermal Resistance

Parameter ^[14]	Description	Test Conditions	100-pin TQFP Package	Unit
Θ _{JA}	Thermal resistance (junction to ambient)	Test conditions follow standard test methods and procedures for measuring thermal impedance, according to EIA/JESD51.	24.63	°C/W
Θ _{JC}	Thermal resistance (junction to case)		2.28	°C/W

AC Test Loads and Waveforms

Figure 2. AC Test Loads and Waveforms

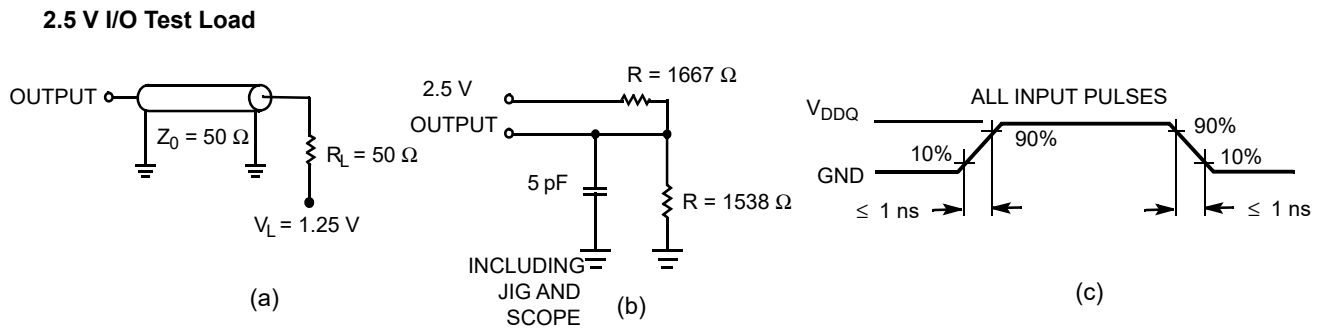

Note

14. Tested initially and after any design or process change that may affect these parameters.

Switching Characteristics

Over the Operating Range

Parameter ^[15, 16]	Description	133 MHz		Unit
		Min	Max	
$t_{POWER}^{[17]}$		1	–	ms
Clock				
t_{CYC}	Clock Cycle Time	7.5	–	ns
t_{CH}	Clock HIGH	2.5	–	ns
t_{CL}	Clock LOW	2.5	–	ns
Output Times				
t_{CDV}	Data Output Valid After CLK Rise	–	6.5	ns
t_{DOH}	Data Output Hold After CLK Rise	2.5	–	ns
t_{CLZ}	Clock to Low Z ^[18, 19, 20]	3.0	–	ns
t_{CHZ}	Clock to High Z ^[18, 19, 20]	–	3.8	ns
$t_{OE\bar{V}}$	\overline{OE} LOW to Output Valid	–	3.0	ns
$t_{OE\bar{L}Z}$	\overline{OE} LOW to Output Low Z ^[18, 19, 20]	0	–	ns
$t_{OE\bar{H}Z}$	\overline{OE} HIGH to Output High Z ^[18, 19, 20]	–	3.0	ns
Setup Times				
t_{AS}	Address Setup Before CLK Rise	1.5	–	ns
t_{ALS}	ADV/LD Setup Before CLK Rise	1.5	–	ns
t_{WES}	\overline{WE} , \overline{BW}_X Setup Before CLK Rise	1.5	–	ns
t_{CENS}	\overline{CEN} Setup Before CLK Rise	1.5	–	ns
t_{DS}	Data Input Setup Before CLK Rise	1.5	–	ns
t_{CES}	Chip Enable Setup Before CLK Rise	1.5	–	ns
Hold Times				
t_{AH}	Address Hold After CLK Rise	0.5	–	ns
t_{ALH}	ADV/LD Hold After CLK Rise	0.5	–	ns
t_{WEH}	\overline{WE} , \overline{BW}_X Hold After CLK Rise	0.5	–	ns
t_{CENH}	\overline{CEN} Hold After CLK Rise	0.5	–	ns
t_{DH}	Data Input Hold After CLK Rise	0.5	–	ns
t_{CEH}	Chip Enable Hold After CLK Rise	0.5	–	ns

Notes

15. Timing reference level is 1.25 V when $V_{DDQ} = 2.5$ V.

16. Test conditions shown in (a) of [Figure 2 on page 11](#) unless otherwise noted.

17. This part has a voltage regulator internally; t_{POWER} is the time that the power is supplied above $V_{DD(minimum)}$ initially, before a read or write operation can be initiated.

18. t_{CHZ} , t_{CLZ} , $t_{OE\bar{L}Z}$, and $t_{OE\bar{H}Z}$ are specified with AC test conditions shown in part (b) of [Figure 2 on page 11](#). Transition is measured ± 200 mV from steady-state voltage.

19. At any supplied voltage and temperature, $t_{OE\bar{H}Z}$ is less than $t_{OE\bar{L}Z}$ and t_{CHZ} is less than t_{CLZ} to eliminate bus contention between SRAMs when sharing the same data bus. These specifications do not imply a bus contention condition, but reflect parameters guaranteed over worst case user conditions. Device is designed to achieve High Z before Low Z under the same system conditions.

20. This parameter is sampled and not 100% tested.

Switching Waveforms

Figure 3. Read/Write Timing [21, 22, 23]

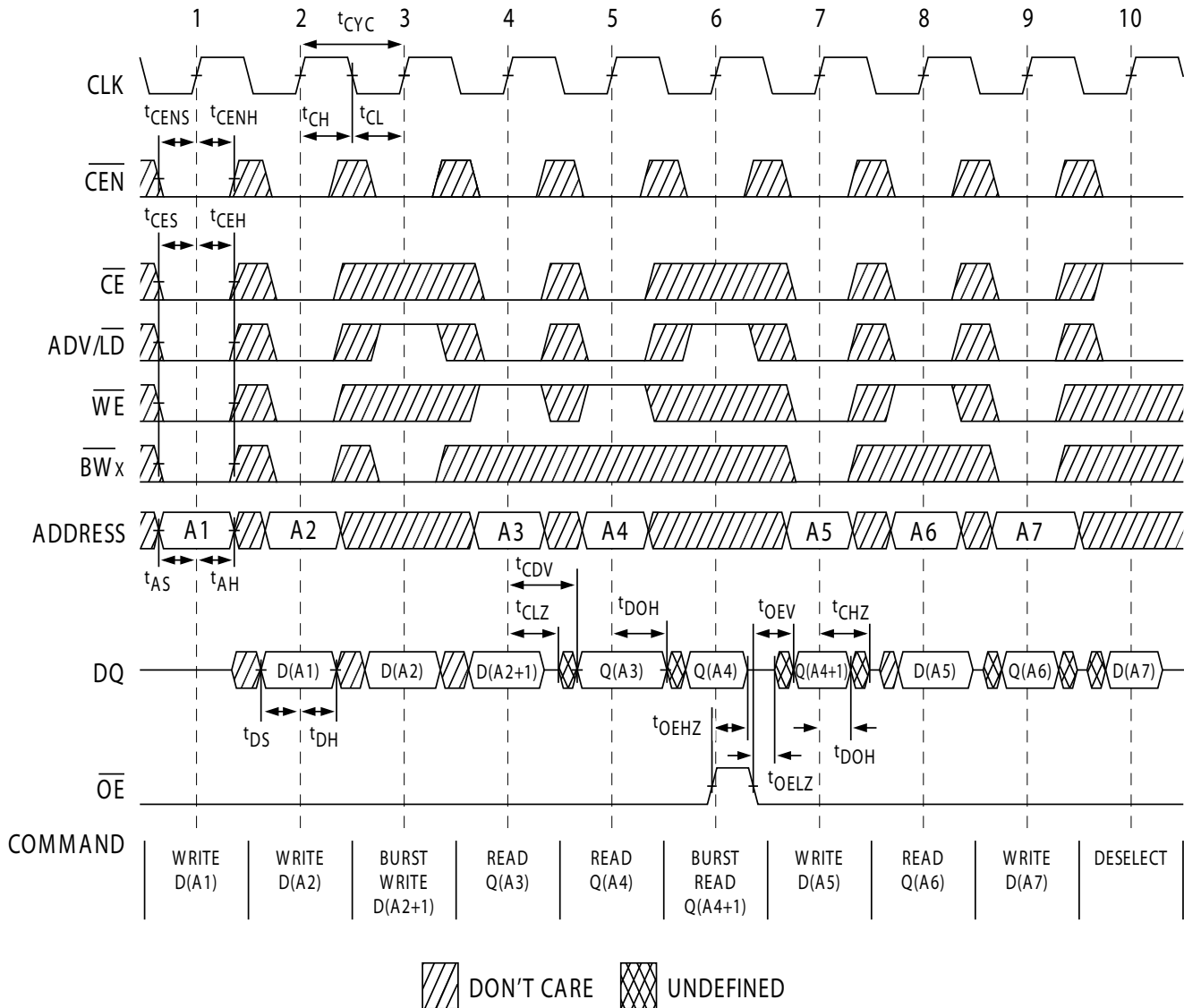

Notes

21. For this waveform \overline{ZZ} is tied LOW.

22. When \overline{CE} is LOW, \overline{CE}_1 is LOW, \overline{CE}_2 is HIGH, and \overline{CE}_3 is LOW. When \overline{CE} is HIGH, \overline{CE}_1 is HIGH, \overline{CE}_2 is LOW or \overline{CE}_3 is HIGH.

23. Order of the Burst sequence is determined by the status of the MODE (0 = Linear, 1 = Interleaved). Burst operations are optional.

Switching Waveforms (continued)

Figure 4. NOP, STALL and DESELECT Cycles [24, 25, 26]

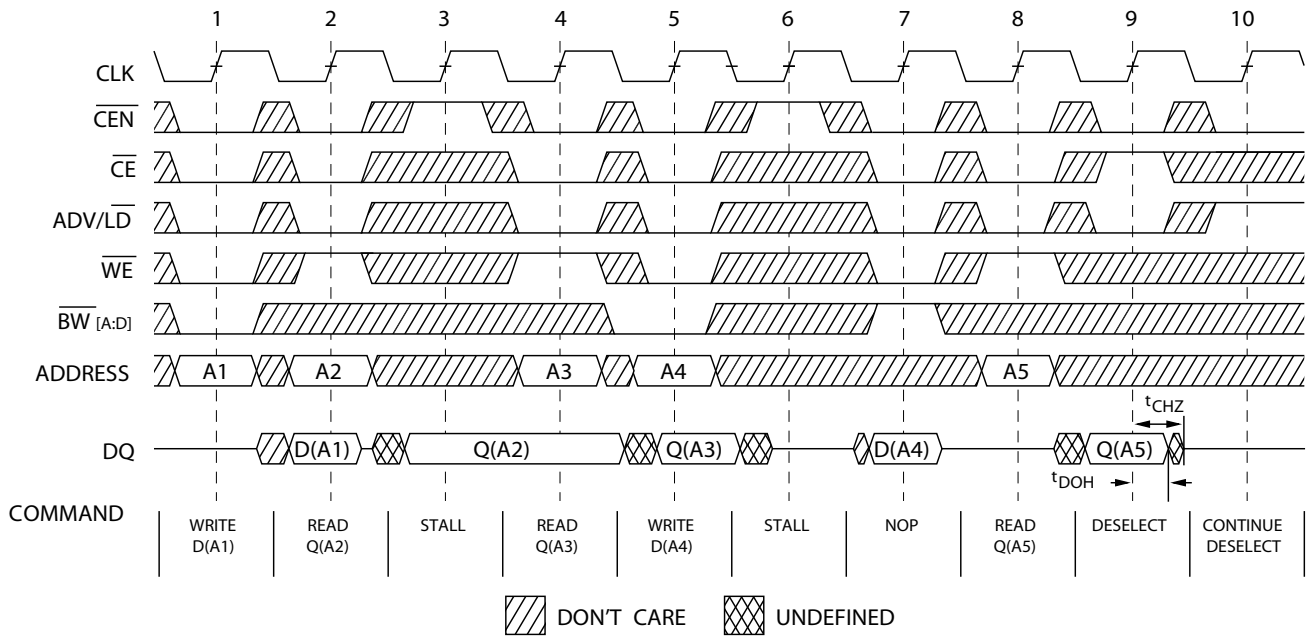

Notes

24. For this waveform ZZ is tied LOW.

25. When \overline{CE} is LOW, \overline{CE}_1 is LOW, CE_2 is HIGH, and \overline{CE}_3 is LOW. When \overline{CE} is HIGH, \overline{CE}_1 is HIGH, CE_2 is LOW or \overline{CE}_3 is HIGH.

26. The IGNORE CLOCK EDGE or STALL cycle (Clock 3) illustrates \overline{CEN} being used to create a pause. A write is not performed during this cycle.

Switching Waveforms (continued)

Figure 5. ZZ Mode Timing [27, 28]

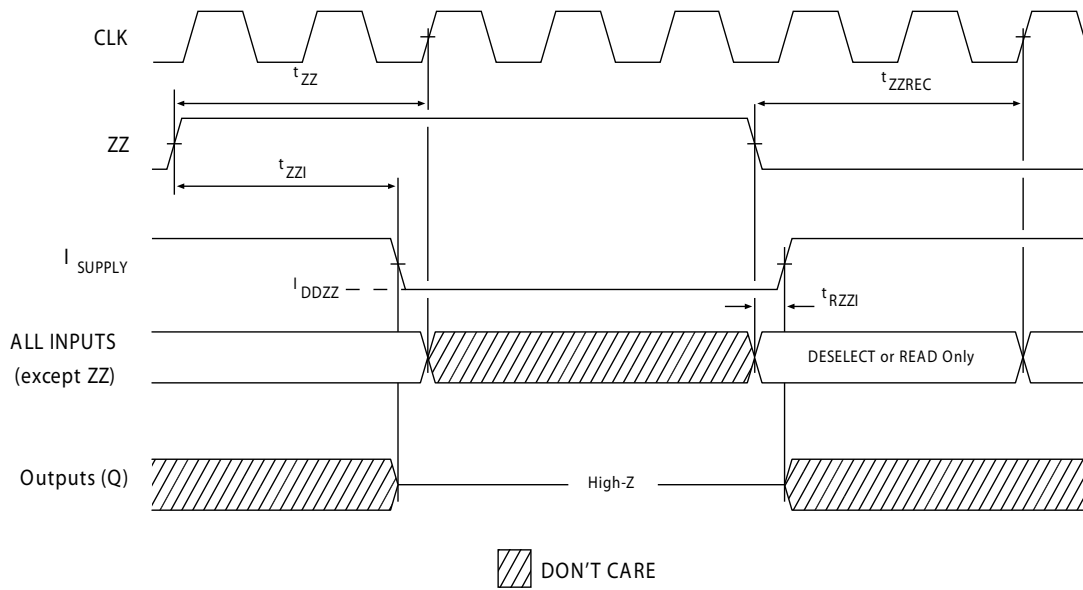

Notes

- 27. Device must be deselected when entering ZZ mode. See [Truth Table on page 8](#) for all possible signal conditions to deselect the device.
- 28. DQs are in high Z when exiting ZZ sleep mode.

Ordering Information

Cypress offers other versions of this type of product in different configurations and features. The following table contains only the list of parts that are currently available.

For a complete listing of all options, visit the Cypress website at www.cypress.com and refer to the product summary page at <http://www.cypress.com/products>, or contact your local sales representative.

Cypress maintains a worldwide network of offices, solution centers, manufacturer’s representatives and distributors. To find the office closest to you, visit us at <http://www.cypress.com/go/datasheet/offices>.

Speed (MHz)	Ordering Code	Package Diagram	Part and Package Type	Operating Range
133	CY7C1471BV25-133AXI	51-85050	100-pin TQFP (14 × 20 × 1.4 mm) Pb-free	Industrial

Ordering Code Definitions

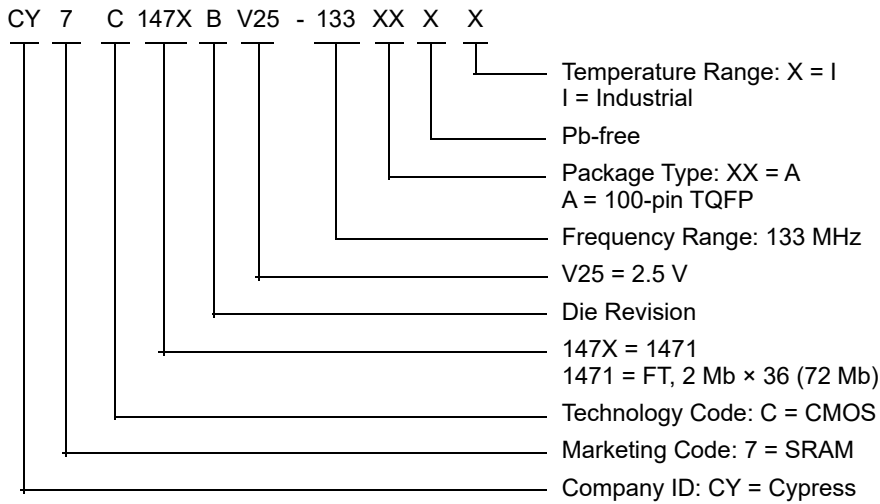

Package Diagrams

Figure 6. 100-pin TQFP (14 × 20 × 1.4 mm) A100RA Package Outline, 51-85050

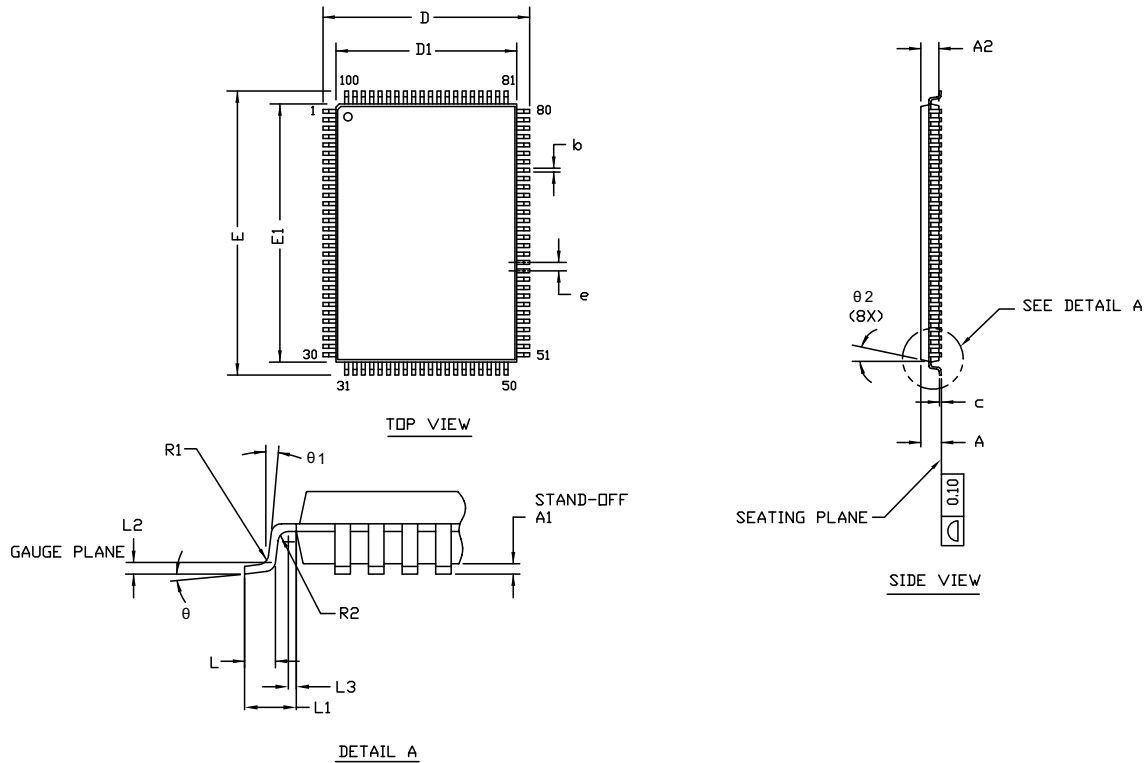

SYMBOL	DIMENSIONS		
	MIN.	NOM.	MAX.
A	—	—	1.60
A1	0.05	—	0.15
A2	1.35	1.40	1.45
D	15.80	16.00	16.20
D1	13.90	14.00	14.10
E	21.80	22.00	22.20
E1	19.90	20.00	20.10
R1	0.08	—	0.20
R2	0.08	—	0.20
θ	0°	—	7°
θ1	0°	—	—
θ2	11°	12°	13°
c	—	—	0.20
b	0.22	0.30	0.38
L	0.45	0.60	0.75
L1	1.00 REF		
L2	0.25 BSC		
L3	0.20	—	—
e	0.65 TYP		

NOTE:

- ALL DIMENSIONS ARE IN MILLIMETERS.
- BODY LENGTH DIMENSION DOES NOT INCLUDE MOLD PROTRUSION/END FLASH. MOLD PROTRUSION/END FLASH SHALL NOT EXCEED 0.0098 in (0.25 mm) PER SIDE. BODY LENGTH DIMENSIONS ARE MAX PLASTIC BODY SIZE INCLUDING MOLD MISMATCH.
- JEDEC SPECIFICATION NO. REF: MS-026.

51-85050 *G

Acronyms

Acronym	Description
BWS	Byte Write Select
CMOS	Complementary Metal Oxide Semiconductor
EIA	Electronic Industries Alliance
FBGA	Fine-Pitch Ball Grid Array
I/O	Input/Output
JEDEC	Joint Electron Devices Engineering Council
LSB	Least Significant Bit
MSB	Most Significant Bit
\overline{OE}	Output Enable
SRAM	Static Random Access Memory
TQFP	Thin Quad Flat Pack
TTL	Transistor-Transistor Logic
\overline{WE}	Write Enable

Document Conventions

Units of Measure

Symbol	Unit of Measure
°C	degree Celsius
μA	microampere
mA	milliampere
mm	millimeter
ms	millisecond
MHz	megahertz
ns	nanosecond
Ω	ohm
%	percent
pF	picofarad
V	volt
W	watt

Document History Page

Document Title: CY7C1471BV25 72-Mbit (2 M × 36) Flow-Through SRAM with NoBL™ Architecture			
Document Number: 001-15013			
Rev.	ECN No.	Issue Date	Description of Change
**	1024500	See ECN	New data sheet.
*A	1274731	See ECN	Updated Switching Waveforms (Corrected typo in the “NOP, STALL and DESELECT Cycles” waveform (Figure 4)).
*B	1562503	See ECN	Updated Features (Removed 1.8 V I/O supply information). Updated IEEE 1149.1 Serial Boundary Scan (JTAG) (Removed 1.8 V I/O supply information). Removed the section “1.8 V TAP AC Test Conditions”. Removed the section “1.8 V TAP AC Output Load Equivalent”. Updated TAP DC Electrical Characteristics and Operating Conditions (Removed 1.8 V I/O supply information). Updated Electrical Characteristics (Removed 1.8 V I/O supply information). Updated AC Test Loads and Waveforms (Removed 1.8 V I/O supply information). Updated Switching Characteristics (Removed 1.8 V I/O supply information).
*C	1897447	See ECN	Updated Electrical Characteristics (Added Note 13 and referred the same note in I _{DD} parameter).
*D	2082487	See ECN	Changed status from Preliminary to Final.
*E	2159486	See ECN	Minor Change (Moved to the external web).
*F	2898501	03/24/2010	Updated Ordering Information (Removed inactive part numbers). Updated Package Diagrams .
*G	3207526	03/28/2011	Updated Ordering Information (Updated part numbers) and added Ordering Code Definitions . Updated Package Diagrams . Updated in new template.
*H	3256583	05/13/2011	Added Acronyms and Units of Measure .
*I	3544389	03/07/2012	Updated Features (Removed CY7C1473BV25 related information). Updated Functional Description (Removed CY7C1473BV25 related information, removed “For best practice recommendations, refer to the Cypress application note AN1064, SRAM System Guidelines.”). Updated Selection Guide (Removed 100 MHz related information). Removed Logic Block Diagram – CY7C1473BV25. Updated Pin Configurations (Removed CY7C1473BV25 related information). Updated Functional Overview (Removed CY7C1473BV25 related information). Updated Truth Table (Removed CY7C1473BV25 related information). Updated IEEE 1149.1 Serial Boundary Scan (JTAG) (Removed CY7C1471BV25 and CY7C1473BV25 related information). Updated Identification Register Definitions (Removed CY7C1473BV25 related information). Updated Scan Register Sizes (Removed Bit Size (× 36) and Bit Size (× 18) columns). Removed “Boundary Scan Exit Order (2 M × 36)” and “Boundary Scan Exit Order (4 M × 18)”. Updated Electrical Characteristics (Removed 100 MHz related information). Updated Capacitance (Removed 165-ball FBGA package related information). Updated Thermal Resistance (Removed 165-ball FBGA package related information). Updated Switching Characteristics (Removed 100 MHz related information). Updated Ordering Information (Updated part numbers). Updated Package Diagrams . Replaced IO with I/O in all instances across the document.

Document History Page (continued)

Document Title: CY7C1471BV25 72-Mbit (2 M × 36) Flow-Through SRAM with NoBL™ Architecture			
Document Number: 001-15013			
Rev.	ECN No.	Issue Date	Description of Change
*J	3564344	03/28/2012	Updated Features (Included 165-ball FBGA package related information). Updated Pin Configurations (Included 165-ball FBGA package related information). Updated IEEE 1149.1 Serial Boundary Scan (JTAG) (Included CY7C1471BV25 related information). Updated Identification Register Definitions (Included CY7C1471BV25 related information). Updated Scan Register Sizes (Included 165-ball FBGA package related information, included Bit Size (× 36) column). Included Boundary Scan Exit Order . Updated Operating Range (Included Commercial Temperature range). Updated Capacitance (Included 165-ball FBGA package related information). Updated Thermal Resistance (Included 165-ball FBGA package related information). Updated Ordering Information (Updated part numbers). Updated Package Diagrams .
*K	4396347	06/02/2014	Updated Package Diagrams : spec 51-85050 – Changed revision from *D to *E. spec 51-85167 – Changed revision from *B to *C. Updated to new template. Completing Sunset Review.
*L	4575272	11/20/2014	Updated Functional Description : Added “For a complete list of related documentation, click here .” at the end.
*M	4785434	06/03/2015	Updated Ordering Information (Updated part numbers). Updated Package Diagrams : Spec 51-85165 – Changed revision from *D to *E. Updated to new template. Completing Sunset Review.
*N	5267388	05/11/2016	Removed references to obsolete devices. Updated the template.
*O	6872683	04/30/2020	Updated to template. Updated Package Diagrams : Spec 51-85050 – Changed revision from *E to *G.

Sales, Solutions, and Legal Information

Worldwide Sales and Design Support

Cypress maintains a worldwide network of offices, solution centers, manufacturer's representatives, and distributors. To find the office closest to you, visit us at [Cypress Locations](#).

Products

Arm [®] Cortex [®] Microcontrollers	cypress.com/arm
Automotive	cypress.com/automotive
Clocks & Buffers	cypress.com/clocks
Interface	cypress.com/interface
Internet of Things	cypress.com/iot
Memory	cypress.com/memory
Microcontrollers	cypress.com/mcu
PSoC	cypress.com/psoc
Power Management ICs	cypress.com/pmic
Touch Sensing	cypress.com/touch
USB Controllers	cypress.com/usb
Wireless Connectivity	cypress.com/wireless

PSoC[®] Solutions

[PSoC 1](#) | [PSoC 3](#) | [PSoC 4](#) | [PSoC 5LP](#) | [PSoC 6 MCU](#)

Cypress Developer Community

[Community](#) | [Code Examples](#) | [Projects](#) | [Video](#) | [Blogs](#) | [Training](#) | [Components](#)

Technical Support

cypress.com/support

© Cypress Semiconductor Corporation, 2007-2020. This document is the property of Cypress Semiconductor Corporation and its subsidiaries ("Cypress"). This document, including any software or firmware included or referenced in this document ("Software"), is owned by Cypress under the intellectual property laws and treaties of the United States and other countries worldwide. Cypress reserves all rights under such laws and treaties and does not, except as specifically stated in this paragraph, grant any license under its patents, copyrights, trademarks, or other intellectual property rights. If the Software is not accompanied by a license agreement and you do not otherwise have a written agreement with Cypress governing the use of the Software, then Cypress hereby grants you a personal, non-exclusive, nontransferable license (without the right to sublicense) (1) under its copyright rights in the Software (a) for Software provided in source code form, to modify and reproduce the Software solely for use with Cypress hardware products, only internally within your organization, and (b) to distribute the Software in binary code form externally to end users (either directly or indirectly through resellers and distributors), solely for use on Cypress hardware product units, and (2) under those claims of Cypress's patents that are infringed by the Software (as provided by Cypress, unmodified) to make, use, distribute, and import the Software solely for use with Cypress hardware products. Any other use, reproduction, modification, translation, or compilation of the Software is prohibited.

TO THE EXTENT PERMITTED BY APPLICABLE LAW, CYPRESS MAKES NO WARRANTY OF ANY KIND, EXPRESS OR IMPLIED, WITH REGARD TO THIS DOCUMENT OR ANY SOFTWARE OR ACCOMPANYING HARDWARE, INCLUDING, BUT NOT LIMITED TO, THE IMPLIED WARRANTIES OF MERCHANTABILITY AND FITNESS FOR A PARTICULAR PURPOSE. No computing device can be absolutely secure. Therefore, despite security measures implemented in Cypress hardware or software products, Cypress shall have no liability arising out of any security breach, such as unauthorized access to or use of a Cypress product. CYPRESS DOES NOT REPRESENT, WARRANT, OR GUARANTEE THAT CYPRESS PRODUCTS, OR SYSTEMS CREATED USING CYPRESS PRODUCTS, WILL BE FREE FROM CORRUPTION, ATTACK, VIRUSES, INTERFERENCE, HACKING, DATA LOSS OR THEFT, OR OTHER SECURITY INTRUSION (collectively, "Security Breach"). Cypress disclaims any liability relating to any Security Breach, and you shall and hereby do release Cypress from any claim, damage, or other liability arising from any Security Breach. In addition, the products described in these materials may contain design defects or errors known as errata which may cause the product to deviate from published specifications. To the extent permitted by applicable law, Cypress reserves the right to make changes to this document without further notice. Cypress does not assume any liability arising out of the application or use of any product or circuit described in this document. Any information provided in this document, including any sample design information or programming code, is provided only for reference purposes. It is the responsibility of the user of this document to properly design, program, and test the functionality and safety of any application made of this information and any resulting product. "High-Risk Device" means any device or system whose failure could cause personal injury, death, or property damage. Examples of High-Risk Devices are weapons, nuclear installations, surgical implants, and other medical devices. "Critical Component" means any component of a High-Risk Device whose failure to perform can be reasonably expected to cause, directly or indirectly, the failure of the High-Risk Device, or to affect its safety or effectiveness. Cypress is not liable, in whole or in part, and you shall and hereby do release Cypress from any claim, damage, or other liability arising from any use of a Cypress product as a Critical Component in a High-Risk Device. You shall indemnify and hold Cypress, its directors, officers, employees, agents, affiliates, distributors, and assigns harmless from and against all claims, costs, damages, and expenses, arising out of any claim, including claims for product liability, personal injury or death, or property damage arising from any use of a Cypress product as a Critical Component in a High-Risk Device. Cypress products are not intended or authorized for use as a Critical Component in any High-Risk Device except to the limited extent that (i) Cypress's published data sheet for the product explicitly states Cypress has qualified the product for use in a specific High-Risk Device, or (ii) Cypress has given you advance written authorization to use the product as a Critical Component in the specific High-Risk Device and you have signed a separate indemnification agreement.

Cypress, the Cypress logo, Spansion, the Spansion logo, and combinations thereof, WICED, PSoC, CapSense, EZ-USB, F-RAM, and Traveo are trademarks or registered trademarks of Cypress in the United States and other countries. For a more complete list of Cypress trademarks, visit cypress.com. Other names and brands may be claimed as property of their respective owners.